

2013
september

Movex

Ingranaggi

L'ingranaggio è uno dei più importanti componenti di un impianto di trasporto. Una ruota ben disegnata assicura una migliore performance e una maggior durata del trasportatore. Offriamo una vasta gamma di ruote fresate e stampate per soddisfare ogni necessità applicativa. Gli ingranaggi Movex nascono da anni di esperienza specifica ed offriamo la più avanzata soluzione:

1. Tutte le ruote sono concepite in due pezzi per un più facile montaggio/smontaggio sull'albero.
2. Tutte le superfici sono lisce per prevenire qualsiasi deposito.
3. I nostri ingranaggi sono ottenuti dal miglior poliammide per assicurare la più lunga durata e resistenza all'usura.
4. Il profilo del dente è specificamente disegnato per offrire la maggior superficie di contatto con la catena e/o il tappeto riducendo la forza esercitata su ciascun dente consentendo una vita più lunga dell'ingranaggio. Il design è sviluppato inoltre tenendo conto dell'allungamento naturale di catena/tappeto, garantendo agli stessi di performare senza problemi entro la soglia di tolleranza dell'allungamento.
5. Le viti in acciaio inossidabile vengono accoppiate con dadi autobloccanti e/o inserti nichelati per consentire un più facile smontaggio/riasssemblaggio anche dopo un lungo periodo dall'installazione.

Sprockets

The sprocket is one of the most important parts of a conveyor. A well designed sprocket will ensure that the conveyor runs smoothly and efficiently for a long time. We have a wide variety of machined and molded sprockets to cover all application needs. Movex Sprockets are designed based on many years of experience to provide you the ultimate solution.

1. *All our sprockets are designed split so that it can be installed and uninstalled from the shaft easily.*
2. *All surfaces and edges from the sprockets are smooth to prevent dirt depositing easily. This makes cleaning easier, maintaining a high hygiene standard.*
3. *Our sprockets are machined from the best polyamide material to ensure longer wear life.*
4. *The sprocket teeth are uniquely designed to provide maximum contact surface with the chain henceforth giving lowest applied force per tooth. This ensures longer wear life for the sprocket. In addition the sprockets are designed in such a way that chain elongation tolerances can be absorbed. This will assure a life-long positive engagement between chain and sprocket.*
5. *Screws used to assemble the sprockets are paired with nickel or zinc plated steel nuts to ensure easy removal.*

Kettenräder

Das Kettenrad ist eines der wichtigsten Komponenten in Transportanlagen. Eine intelligentes Design gewährleistet einen ruhigen Lauf und Effizienz für einen langen Zeitraum. Wir bieten ein umfangreiches Programm in gefräster oder gespritzter Ausführung um Ihren Anforderungen entgegen zu kommen. Movex Kettenräder basieren auf jahrelangen Erfahrungen aus den verschiedenen Industrien und vereinen diese Erkenntnisse in einem innovativem Design.

1. *Alle unsere Kettenräder sind zweigeteilt, d.h. einfache Montage und Demontage ohne großen Zeitaufwand*
2. *Alle Oberflächen sind glatt um Schmutzablagerungen zu vermeiden dies erleichtert eine schnelle und einfache Reinigung.*
3. *Die Materialien sind so gewählt um eine längere Lebensdauer bieten zu können*
4. *Die Zahnform ist so gewählt um maximale Kontaktfläche mit der Kette / Mattenkette zu erzielen. Dies ermöglicht eine länger Lebensdauer des Kettenrades. Die Ausführung ist so gewählt das eine Kettenlängung vom Kettenrad aufgenommen werden kann ohne sofort die Kette tauschen zu müssen.*
5. *Schrauben aus Edelstahl verbunden mit einer selbstsichernde Mutter aus vernickeltem Stahl. Dies garantiert eine problemlose Demontage auch noch nach Jahren.*

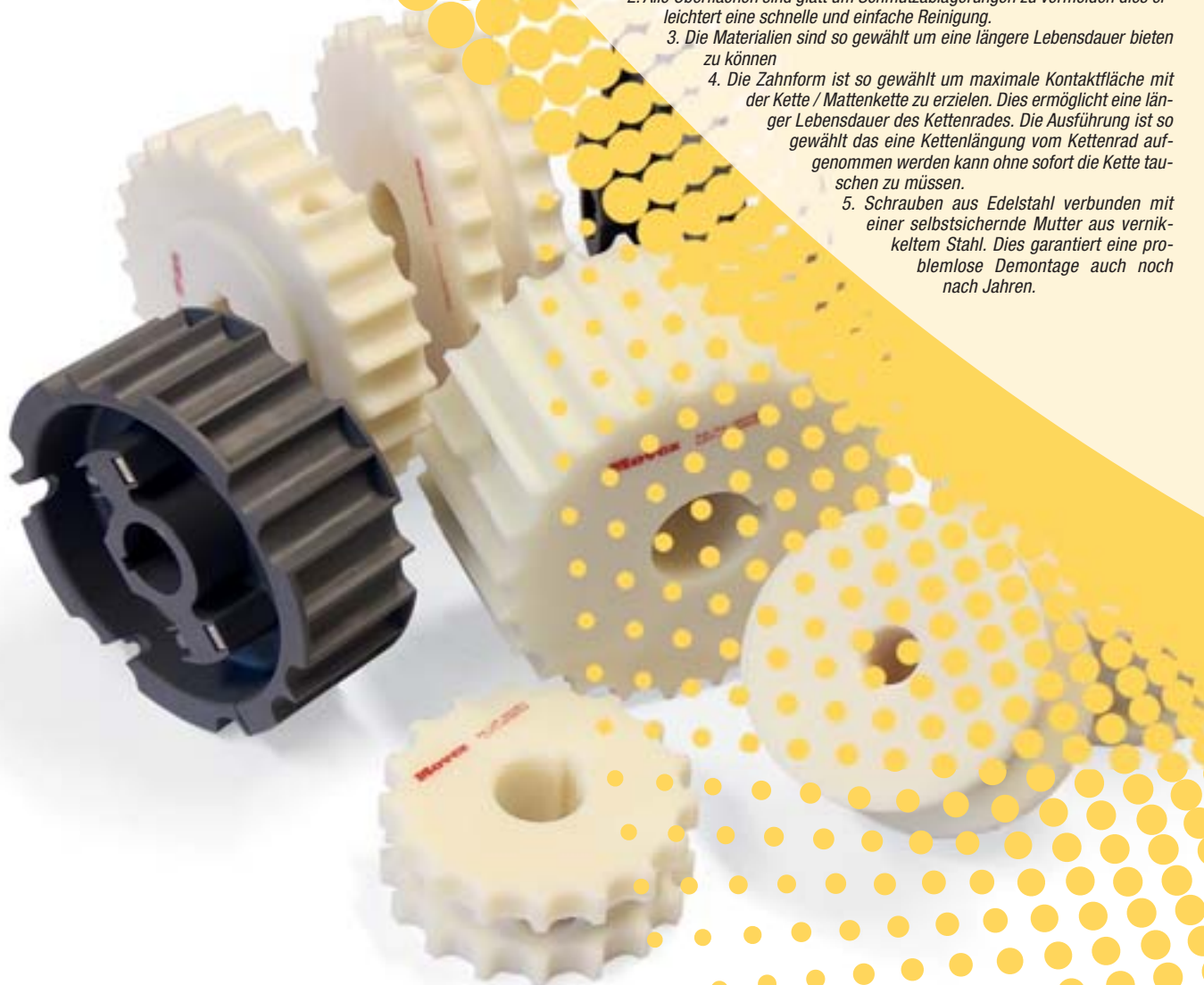

**Technical information
tolerances and dimensions**

SPLIT SPROCKET / ISO 773 - DIN 6885					
ØD		A		H	
Nom.	Tol.	Nom.	Tol.	Nom.	Tol.
20	P9	6	P9	22.8	+0.1/0
25	P9	8	P9	28.3	+0.2/0
30	P9	8	P9	33.3	+0.2/0
35	P9	10	P9	38.3	+0.2/0
40	P9	12	P9	43.3	+0.2/0
45	P9	14	P9	48.8	+0.2/0
50	P9	14	P9	53.8	+0.2/0

SPLT SPROCKET "PLUS" VERSION					
D		A		H	
Nom.	Tol.	Nom.	Tol.	Nom.	Tol.
20	+0.25/+0.15	6	+0.2/+0.3	22.8	+0.2/+0.4
25	+0.25/+0.15	8	+0.2/+0.3	28.3	+0.2/+0.4
30	+0.25/+0.15	8	+0.2/+0.3	33.3	+0.2/+0.4
35	+0.25/+0.15	10	+0.2/+0.3	38.3	+0.2/+0.4
40	+0.25/+0.15	12	+0.2/+0.3	43.3	+0.2/+0.4
45	+0.25/+0.15	14	+0.2/+0.3	48.8	+0.2/+0.4
50	+0.25/+0.15	14	+0.2/+0.3	53.8	+0.2/+0.4

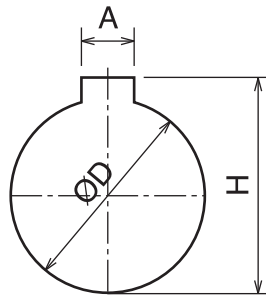

IDLER	
Ød	
Nom.	Tol.
20	+0.3/+0.4
25	+0.3/+0.4
30	+0.3/+0.4
35	+0.3/+0.4
40	+0.3/+0.4
45	+0.3/+0.4
50	+0.3/+0.4

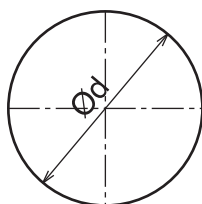

SQUARE BORE	
AxA	
Nom.	Tol.
20x20	+0.3/+0.5
25x25	+0.3/+0.5
30x30	+0.3/+0.5
35x35	+0.3/+0.5
40x40	+0.3/+0.5
45x45	+0.3/+0.5
50x50	+0.3/+0.5

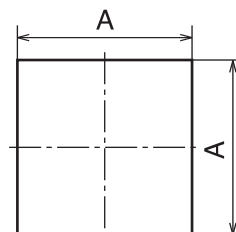

chain sprockets

Series 815



pag. 30

Series 815



pag. 30

Series 815



pag. 31

Series 815



pag. 31

Series 881



pag. 32

Series 881



pag. 32

Series 881



pag. 33

Series 881



pag. 33

Series 805



pag. 34

Series 805



pag. 34

Series 8157



pag. 35

Series 8157



pag. 35

Series 820



pag. 36

Series 820



pag. 36

Series 820



pag. 37

Series 820



pag. 37

Series 880



pag. 38

Series 880



pag. 38

Series 880



pag. 39

Series 880



pag. 39

Series 882



pag. 40

Series 882



pag. 40

Series 882



pag. 41

Series 882



pag. 41

Series 512



pag. 42

Series 512



pag. 42

Series 815



pag. 43

Series 8157



pag. 43

Series 805



pag. 44

Series CC600



pag. 44

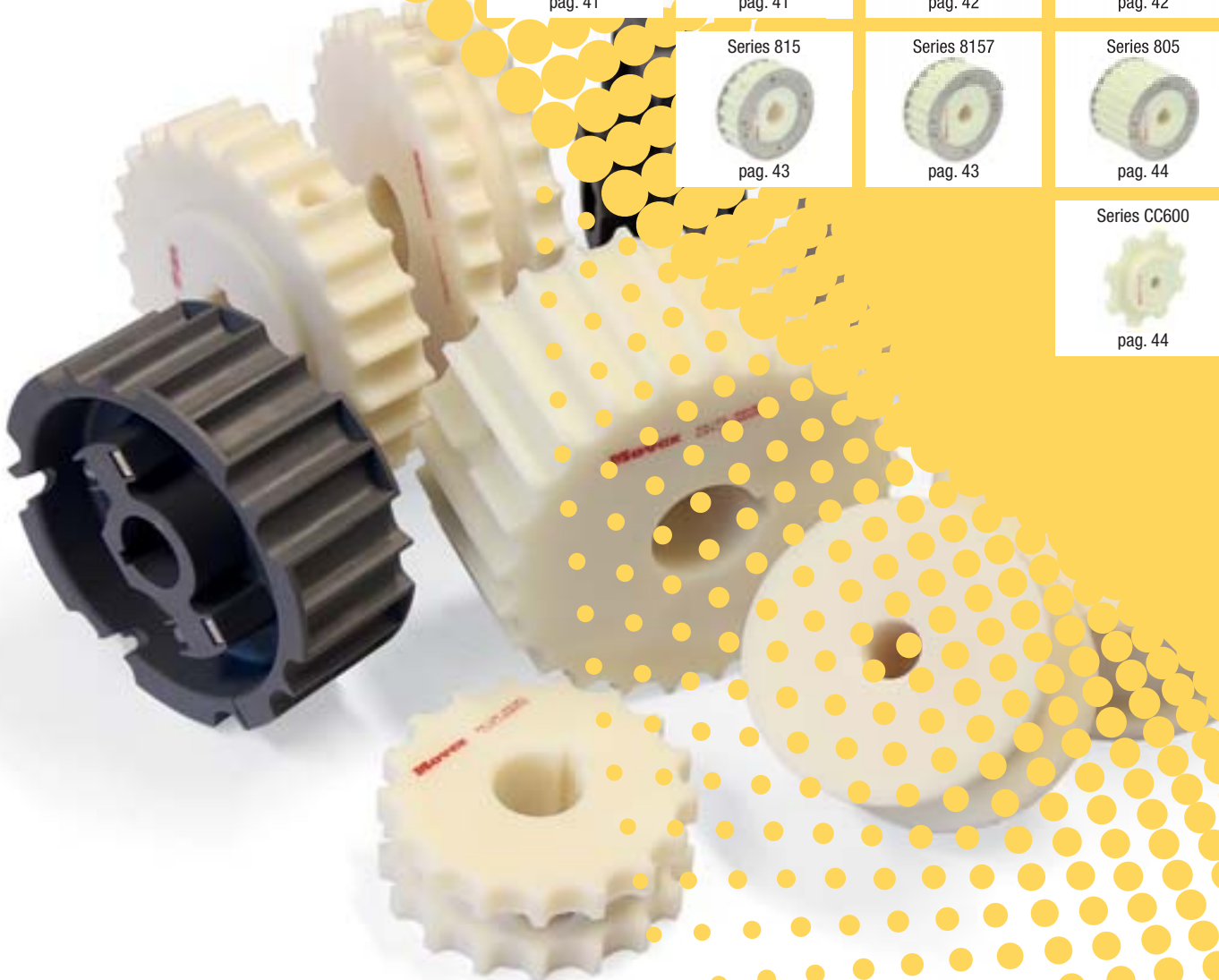

Materiale:	Material:	Materialien:
Poliammide	Polyamide	Polyamid
Viti: Acciaio inox	Screws: Stainless steel	Schrauben: Edelstahl
Dadi: ferro zincato	Nuts: zinc plated steel	Mutter: verzinkter Stahl



Ruota traino divisa, fresata / Split drive sprocket, machined / geteiltes Antriebskettenrad, gefräst

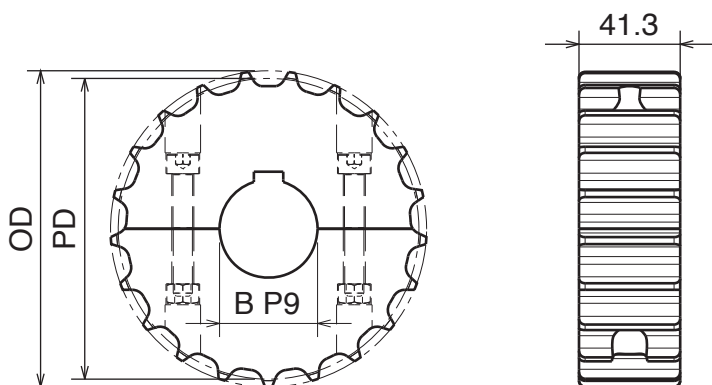

Part	Article-Nr.	Z-	Bore	PD	OD
501	50101	17	25	105,5	103,9
501	50102		30		
501	50103		35		
501	50104		40		
502	50201	19	25	117,3	117,0
502	50202		30		
502	50203		35		
502	50204		40		
503	50301	21	25	129,3	129,0
503	50302		30		
503	50303		35		
503	50304		40		
504	50401	23	25	141,2	142,0
504	50402		30		
504	50403		35		
504	50404		40		
505	50501	25	25	153,2	154,0
505	50502		30		
505	50503		35		
505	50504		40		
506	50601	27	25	165,2	166,8
506	50602		30		
506	50603		35		
506	50604		40		
507	50701	29	25	177,2	178,5
507	50702		30		
507	50703		35		
507	50704		40		



Ruota rinvio divisa, fresata / Split idler sprocket, machined / geteiltes Umlenkrad, gefräst

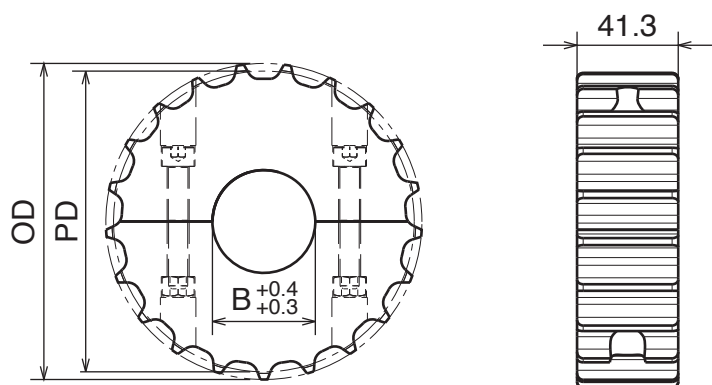

Part	Article-Nr.	Z-	Bore	PD	OD
501	50150	17	18*	105,5	103,9
501	50151		25		
501	50152		30		
501	50153		35		
501	50154		40		
502	50250	19	18*	117,3	117,0
502	50251		25		
502	50252		30		
502	50253		35		
502	50254		40		
503	50350	21	18*	129,3	129,0
503	50351		25		
503	50352		30		
503	50353		35		
503	50354		40		
504	50450	23	18*	141,2	142,0
504	50451		25		
504	50452		30		
504	50453		35		
504	50454		40		
505	50550	25	18*	153,2	154,0
505	50551		25		
505	50552		30		
505	50553		35		
505	50554		40		
506	50650	27	18*	165,2	166,8
506	50651		25		
506	50652		30		
506	50653		35		
506	50654		40		
507	50750	29	18*	177,2	178,5
507	50751		25		
507	50752		30		
507	50753		35		
507	50754		40		

Materiale:	Material:	Materialien:
Poliammide rinforzato	Polyamide reinforced	Verstärktes Polyamid
Viti: Acciaio inox	Screws: Stainless steel	Schrauben: Edelstahl
Dadi: ottone nichelato	Nuts: nickel plated brass	Mutter: Messing vernickelt

Ruota traino divisa, stampata / Split drive sprocket, molded / geteiltes Antriebskettenrad, gespritzt

Part	Article-Nr.	Z-	Bore	PD	OD
508	50801	21	25	129,3	129,0
508	50802		30		
508	50803		35		
508	50804		40		
509	50901	23	25	141,2	142,0
509	50902		30		
509	50903		35		
509	50904		40		
510	51001	25	25	153,2	154,0
510	51002		30		
510	51003		35		
510	51004		40		

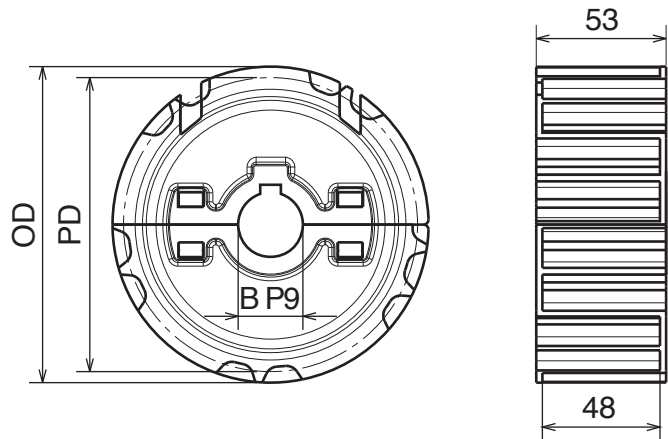

Ruota rinvio divisa, stampata / Split idler sprocket, molded / geteiltes Umlenkrad, gespritzt

Part	Article-Nr.	Z-	Bore	PD	OD
508	50851	21	25	129,3	129,0
508	50852		30		
508	50853		35		
508	50854		40		
509	50951	23	25	141,2	142,0
509	50952		30		
509	50953		35		
509	50954		40		
510	51051	25	25	153,2	154,0
510	51052		30		
510	51053		35		
510	51054		40		

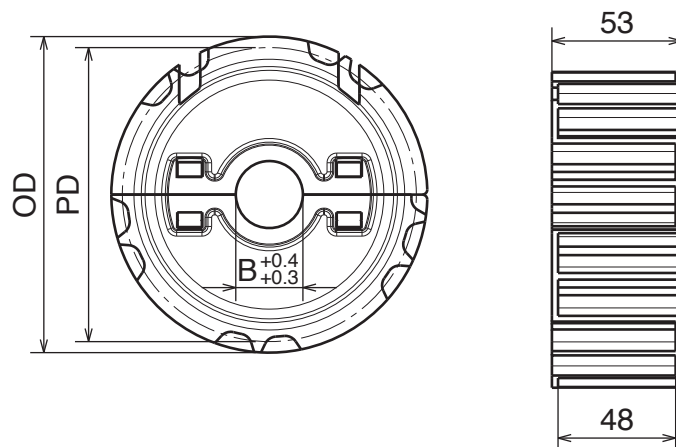

Materiale:	Material:	Materialien:
Poliammide	Polyamide	Polyamid
Viti: Acciaio inox	Screws: Stainless steel	Schrauben: Edelstahl
Dadi: ferro zincato	Nuts: zinc plated steel	Mutter: verzinkter Stahl



Ruota traino divisa, fresata / Split drive sprocket, machined / geteiltes Antriebskettenrad, gefräst

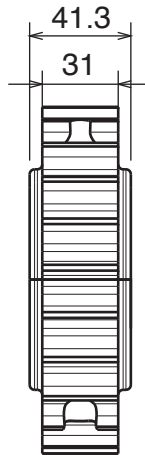
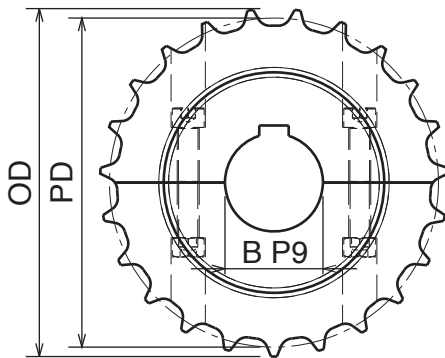

Part	Article-Nr.	Z-	Bore	PD	OD
511	51101	17	25	105,5	103,9
511	51102		30		
511	51103		35		
511	51104		40		
512	51201	19	25	117,3	117,0
512	51202		30		
512	51203		35		
512	51204		40		
513	51301	21	25	129,3	129,0
513	51302		30		
513	51303		35		
513	51304		40		
514	51401	23	25	141,2	142,0
514	51402		30		
514	51403		35		
514	51404		40		
515	51501	25	25	153,2	154,0
515	51502		30		
515	51503		35		
515	51504		40		
516	51601	27	25	165,2	166,8
516	51602		30		
516	51603		35		
516	51604		40		
517	51701	29	25	177,2	178,5
517	51702		30		
517	51703		35		
517	51704		40		



Ruota rinvio divisa, fresata / Split idler sprocket, machined / geteiltes Umlenkrad, gefräst

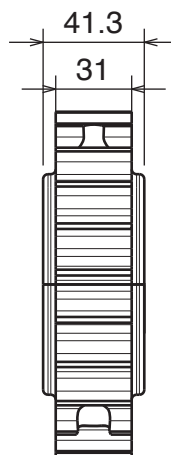
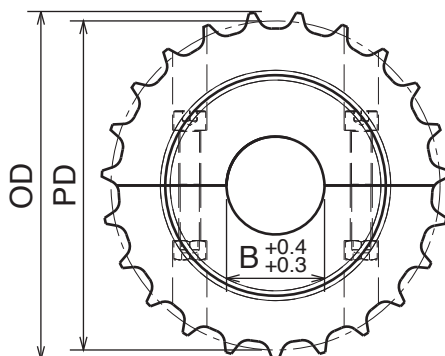

Part	Article-Nr.	Z-	Bore	PD	OD
511	51150	17	18*	105,5	103,9
511	51151		25		
511	51152		30		
511	51153		35		
511	51154		40		
512	51250	19	18*	117,3	117,0
512	51251		25		
512	51252		30		
512	51253		35		
512	51254		40		
513	51350	21	18*	129,3	129,0
513	51351		25		
513	51352		30		
513	51353		35		
513	51354		40		
514	51450	23	18*	141,2	142,0
514	51451		25		
514	51452		30		
514	51453		35		
514	51454		40		
515	51550	25	18*	153,2	154,0
515	51551		25		
515	51552		30		
515	51553		35		
515	51554		40		
516	51650	27	18*	165,2	166,8
516	51651		25		
516	51652		30		
516	51653		35		
516	51654		40		
517	51750	29	18*	177,2	178,5
517	51751		25		
517	51752		30		
517	51753		35		
517	51754		40		

Materiale:	Material:	Materialien:
Poliammide rinforzato	Polyamide reinforced	Verstärktes Polyamid
Viti: Acciaio inox	Screws: Stainless steel	Schrauben: Edelstahl
Dadi: ottone nichelato	Nuts: nickel plated brass	Mutter: Messing vernickelt

Ruota traino divisa, stampata / Split drive sprocket, molded / geteiltes Antriebskettenrad, gespritzt

Part	Article-Nr.	Z-	Bore	PD	OD
518	51801	21	25	129,3	129,0
518	51802		30		
518	51803		35		
518	51804		40		
519	51901	23	25	141,2	142,0
519	51902		30		
519	51903		35		
519	51904		40		
520	52001	25	25	153,2	154,0
520	52002		30		
520	52003		35		
520	52004		40		

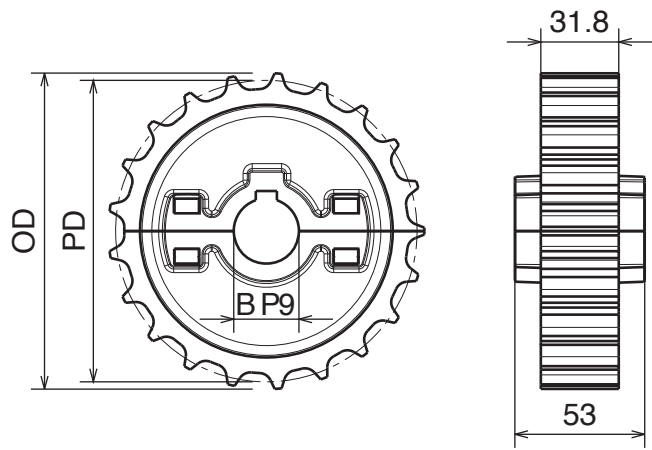

Ruota rinvio divisa, stampata / Split idler sprocket, molded / geteiltes Umlenkrad, gespritzt

Part	Article-Nr.	Z-	Bore	PD	OD
518	51851	21	25	129,3	129,0
518	51852		30		
518	51853		35		
518	51854		40		
519	51951	23	25	141,2	142,0
519	51952		30		
519	51953		35		
519	51954		40		
520	52051	25	25	153,2	154,0
520	52052		30		
520	52053		35		
520	52054		40		

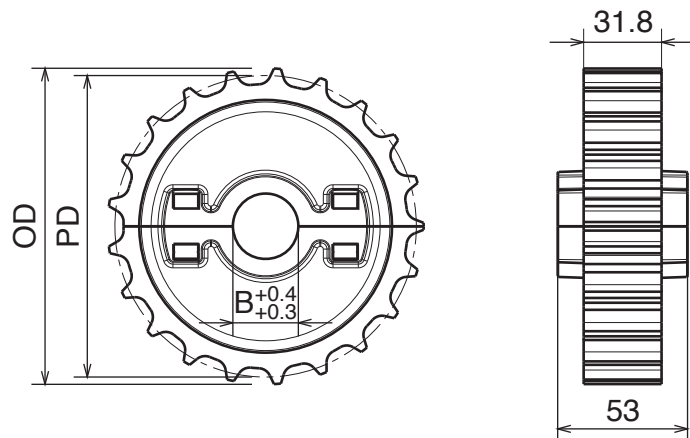

805-821

Ruote Fresate
Machined Sprockets
Gefräste Kettenräder

Materiale:	Material:	Materialien:
Poliammide	Polyamide	Polyamid
Viti: Acciaio inox	Screws: Stainless steel	Schrauben: Edelstahl
Dadi: ferro zincato	Nuts: zinc plated steel	Mutter: verzinkter Stahl



Ruota traino divisa, fresata / Split drive sprocket, machined / geteiltes Antriebskettenrad, gefräst

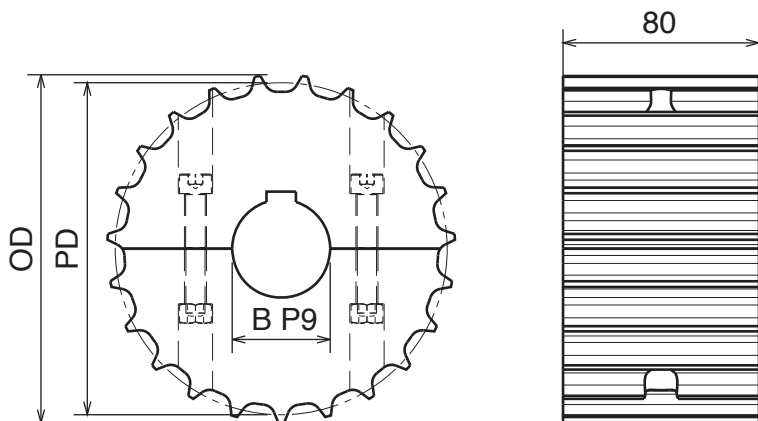

Part	Article-Nr.	Z-	Bore	PD	OD
521	52101	17	25	105,5	103,9
521	52102		30		
521	52103		35		
521	52104		40		
522	52201	19	25	117,3	117,0
522	52202		30		
522	52203		35		
522	52204		40		
523	52301	21	25	129,3	129,0
523	52302		30		
523	52303		35		
523	52304		40		
524	52401	23	25	141,2	142,0
524	52402		30		
524	52403		35		
524	52404		40		
525	52501	25	25	153,2	154,0
525	52502		30		
525	52503		35		
525	52504		40		
526	52601	27	25	165,2	166,8
526	52602		30		
526	52603		35		
526	52604		40		
527	52701	29	25	177,2	178,5
527	52702		30		
527	52703		35		
527	52704		40		



Ruota rinvio divisa, fresata / Split idler sprocket, machined / geteiltes Umlenkrad, gefräst

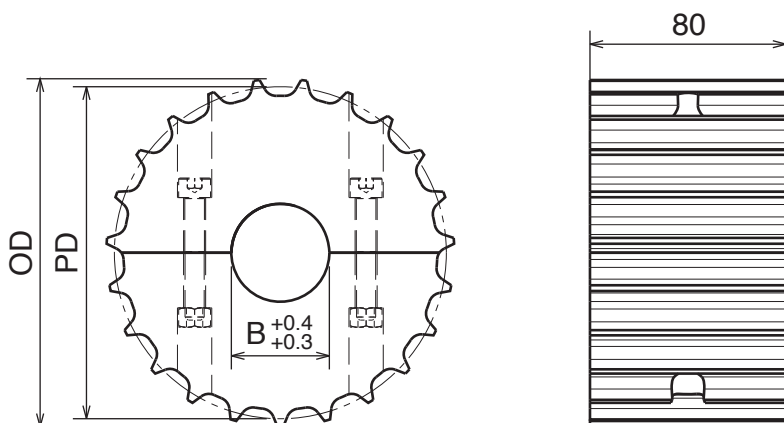

Part	Article-Nr.	Z-	Bore	PD	OD
521	52150	17	18*	105,5	103,9
521	52151		25		
521	52152		30		
521	52153		35		
521	52154		40		
522	52250	19	18*	117,3	117,0
522	52251		25		
522	52252		30		
522	52253		35		
522	52254		40		
523	52350	21	18*	129,3	129,0
523	52351		25		
523	52352		30		
523	52353		35		
523	52354		40		
524	52450	23	18*	141,2	142,0
524	52451		25		
524	52452		30		
524	52453		35		
524	52454		40		
525	52550	25	18*	153,2	154,0
525	52551		25		
525	52552		30		
525	52553		35		
525	52554		40		
526	52650	27	18*	165,2	166,8
526	52651		25		
526	52652		30		
526	52653		35		
526	52654		40		
527	52750	29	18*	177,2	178,5
527	52751		25		
527	52752		30		
527	52753		35		
527	52754		40		

Materiale:	Material:	Materialien:
Poliammide	Polyamide	Polyamid
Viti: Acciaio inox	Screws: Stainless steel	Schrauben: Edelstahl
Dadi: ferro zincato	Nuts: zinc plated steel	Mutter: verzinkter Stahl

Ruota traino divisa, fresata / Split drive sprocket, machined / geteiltes Antriebskettenrad, gefräst

Part	Article-Nr.	Z-	Bore	PD	OD
528	52801	17	25	105,5	103,9
528	52802		30		
528	52803		35		
528	52804		40		
529	52901	19	25	117,3	117,0
529	52902		30		
529	52903		35		
529	52904		40		
530	53001	21	25	129,3	129,0
530	53002		30		
530	53003		35		
530	53004		40		
531	53101	23	25	141,2	142,0
531	53102		30		
531	53103		35		
531	53104		40		
532	53201	25	25	153,2	154,0
532	53202		30		
532	53203		35		
532	53204		40		
533	53301	27	25	165,2	166,8
533	53302		30		
533	53303		35		
533	53304		40		
534	53401	29	25	177,2	178,5
534	53402		30		
534	53403		35		
534	53404		40		

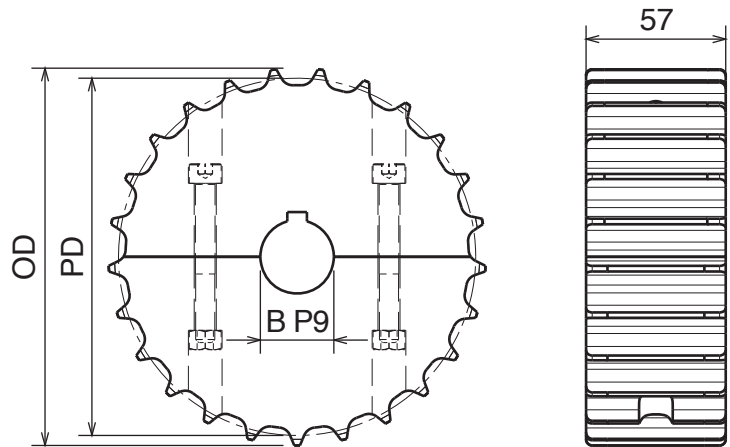

Ruota rinvio divisa, fresata / Split idler sprocket, machined / geteiltes Umlenkrad, gefräst

Part	Article-Nr.	Z-	Bore	PD	OD
528	52850	17	18*	105,5	103,9
528	52851		25		
528	52852		30		
528	52853		35		
528	52854		40		
529	52950	19	18*	117,3	117,0
529	52951		25		
529	52952		30		
529	52953		35		
529	52954		40		
530	53050	21	18*	129,3	129,0
530	53051		25		
530	53052		30		
530	53053		35		
530	53054		40		
531	53150	23	18*	141,2	142,0
531	53151		25		
531	53152		30		
531	53153		35		
531	53154		40		
532	53250	25	18*	153,2	154,0
532	53251		25		
532	53252		30		
532	53253		35		
532	53254		40		
533	53350	27	18*	165,2	166,8
533	53351		25		
533	53352		30		
533	53353		35		
533	53354		40		
534	53450	29	18*	177,2	178,5
534	53451		25		
534	53452		30		
534	53453		35		
534	53454		40		

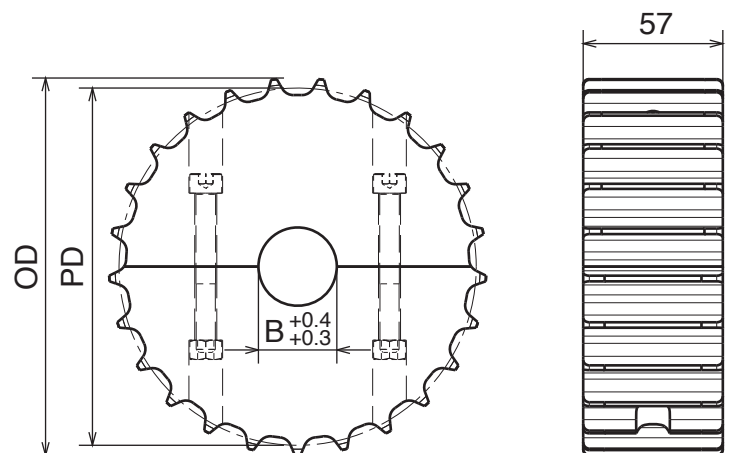

Materiale:	Material:	Materialien:
Poliammide	Polyamide	Polyamid
Viti: Acciaio inox	Screws: Stainless steel	Schrauben: Edelstahl
Dadi: ferro zincato	Nuts: zinc plated steel	Mutter: verzinkter Stahl



Ruota traino divisa, fresata / Split drive sprocket, machined / geteiltes Antriebskettenrad, gefräst

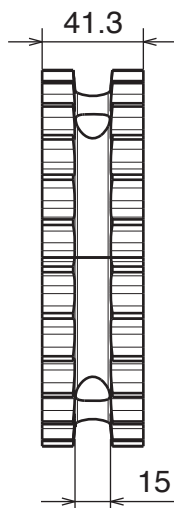
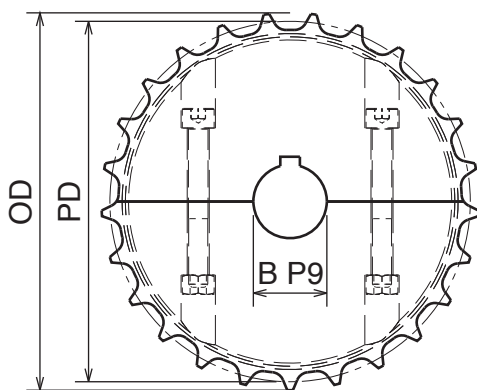

Part	Article-Nr.	Z-	Bore	PD	OD
535	53501	17	25	105,5	103,9
535	53502		30		
535	53503		35		
535	53504		40		
536	53601	19	25	117,3	117,0
536	53602		30		
536	53603		35		
536	53604		40		
537	53701	21	25	129,3	129,0
537	53702		30		
537	53703		35		
537	53704		40		
538	53801	23	25	141,2	142,0
538	53802		30		
538	53803		35		
538	53804		40		
539	53901	25	25	153,2	154,0
539	53902		30		
539	53903		35		
539	53904		40		
540	54001	27	25	165,2	166,8
540	54002		30		
540	54003		35		
540	54004		40		
541	54101	29	25	177,2	178,5
541	54102		30		
541	54103		35		
541	54104		40		



Ruota rinvio divisa, fresata / Split idler sprocket, machined / geteiltes Umlenkrad, gefräst

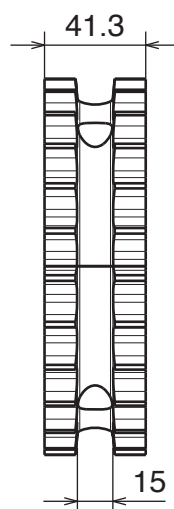
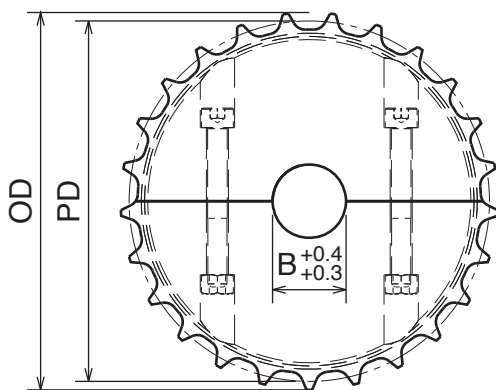

Part	Article-Nr.	Z-	Bore	PD	OD
535	53550	17	18*	105,5	103,9
535	53551		25		
535	53552		30		
535	53553		35		
535	53554		40		
536	53650	19	18*	117,3	117,0
536	53651		25		
536	53652		30		
536	53653		35		
536	53654		40		
537	53750	21	18*	129,3	129,0
537	53751		25		
537	53752		30		
537	53753		35		
537	53754		40		
538	53850	23	18*	141,2	142,0
538	53851		25		
538	53852		30		
538	53853		35		
538	53854		40		
539	53950	25	18*	153,2	154,0
539	53951		25		
539	53952		30		
539	53953		35		
539	53954		40		
540	54050	27	18*	165,2	166,8
540	54051		25		
540	54052		30		
540	54053		35		
540	54054		40		
541	54150	29	18*	177,2	178,5
541	54151		25		
541	54152		30		
541	54153		35		
541	54154		40		

Materiale:	Material:	Materialien:
Poliammide rinforzato	Polyamide reinforced	Verstärktes Polyamid
Viti: Acciaio inox	Screws: Stainless steel	Schrauben: Edelstahl
Dadi: ottone nichelato	Nuts: nickel plated brass	Mutter: Messing vernickelt

Ruota traino divisa, stampata / Split drive sprocket, molded / geteiltes Antriebskettenrad, gespritzt

Part	Article-Nr.	Z-	Bore	PD	OD
542	54201	21	25	129,3	129,0
542	54202		30		
542	54203		35		
542	54204		40		
543	54301	23	25	141,2	142,0
543	54302		30		
543	54303		35		
543	54304		40		
544	54401	25	25	153,2	154,0
544	54402		30		
544	54403		35		
544	54404		40		

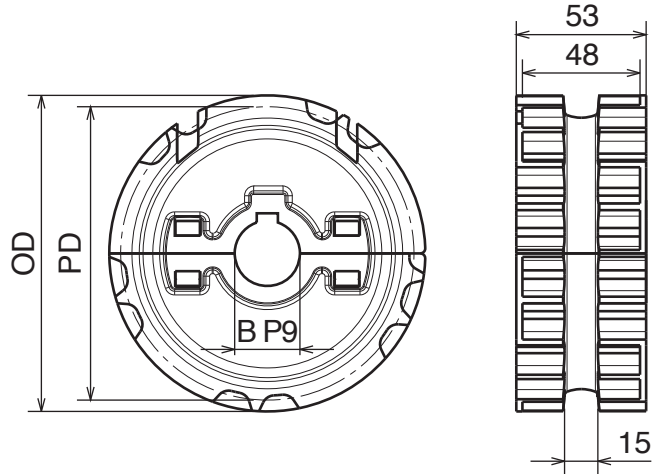

Ruota rinvio divisa, stampata / Split idler sprocket, molded / geteiltes Umlenkrad, gespritzt

Part	Article-Nr.	Z-	Bore	PD	OD
542	54251	21	25	129,3	129,0
542	54252		30		
542	54253		35		
542	54254		40		
543	54351	23	25	141,2	142,0
543	54352		30		
543	54353		35		
543	54354		40		
544	54451	25	25	153,2	154,0
544	54452		30		
544	54453		35		
544	54454		40		

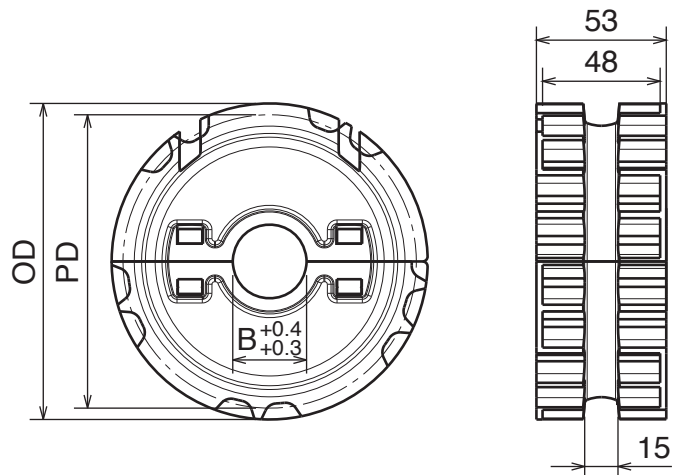

Materiale:	Material:	Materialien:
Poliammide	Polyamide	Polyamid
Viti: Acciaio inox	Screws: Stainless steel	Schrauben: Edelstahl
Dadi: ferro zincato	Nuts: zinc plated steel	Mutter: verzinkter Stahl



Ruota traino divisa, fresata / Split drive sprocket, machined / geteiltes Antriebskettenrad, gefräst

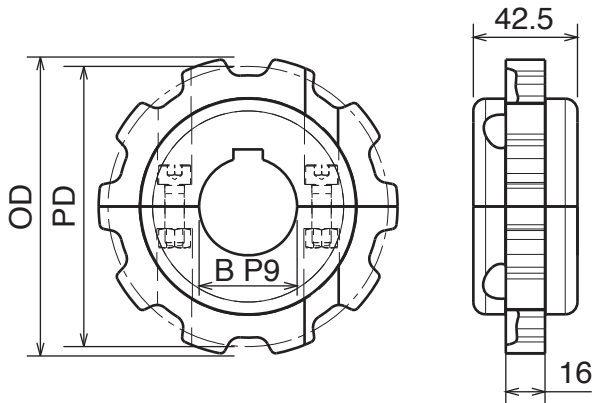

Part	Article-Nr.	Z-	Bore	PD	OD
545	54501	9	25	111,4	110,0
545	54502		30		
545	54503		35		
545	54504		40		
546	54601	10	25	123,3	122,0
546	54602		30		
546	54603		35		
546	54604		40		
547	54701	11	25	135,2	135,0
547	54702		30		
547	54703		35		
547	54704		40		
548	54801	12	25	147,2	147,3
548	54802		30		
548	54803		35		
548	54804		40		



Ruota rinvio divisa, fresata / Split idler sprocket, machined / geteiltes Umlenkrad, gefräst

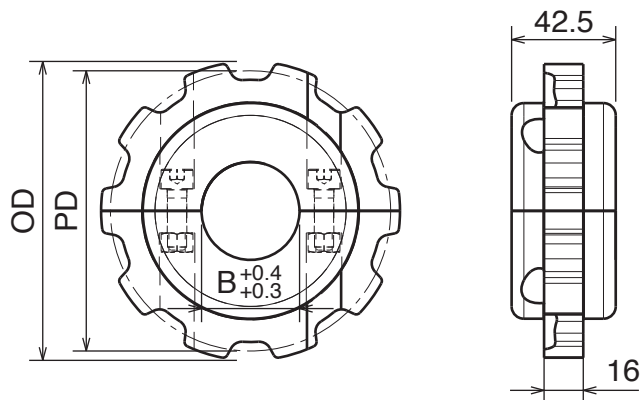

Part	Article-Nr.	Z-	Bore	PD	OD
545	54550	9	18*	111,4	110,0
545	54551		25		
545	54552		30		
545	54553		35		
545	54554		40		
546	54650	10	18*	123,3	122,0
546	54651		25		
546	54652		30		
546	54653		35		
546	54654		40		
547	54750	11	18*	135,2	135,0
547	54751		25		
547	54752		30		
547	54753		35		
547	54754		40		
548	54850	12	18*	147,2	147,3
548	54851		25		
548	54852		30		
548	54853		35		
548	54854		40		

Materiale:	Material:	Materialien:
Poliammide rinforzato	Polyamide reinforced	Verstärktes Polyamid
Viti: Acciaio inox	Screws: Stainless steel	Schrauben: Edelstahl
Dadi: ottone nichelato	Nuts: nickel plated brass	Mutter: Messing vernickelt

Ruota traino divisa, stampata / Split drive sprocket, molded / geteiltes Antriebskettenrad, gespritzt

Part	Article-Nr.	Z-	Bore	PD	OD
549	54901	10	25	123,2	122,0
549	54902		30		
549	54903		35		
549	54904		40		
550	55001	12	25	147,2	147,3
550	55002		30		
550	55003		35		
550	55004		40		

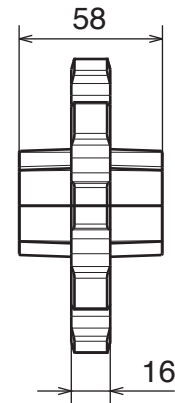
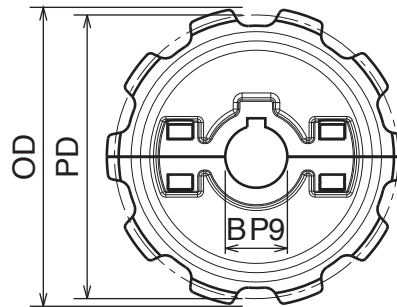

Ruota rinvio divisa, stampata / Split idler sprocket, molded / geteiltes Umlenkrad, gespritzt

Part	Article-Nr.	Z-	Bore	PD	OD
549	54951	10	25	123,2	122,0
549	54952		30		
549	54953		35		
549	54954		40		
550	55051	12	25	147,2	147,3
550	55052		30		
550	55053		35		
550	55054		40		

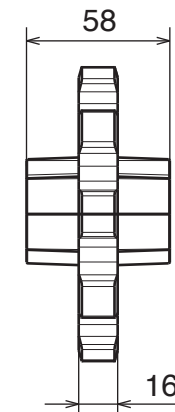
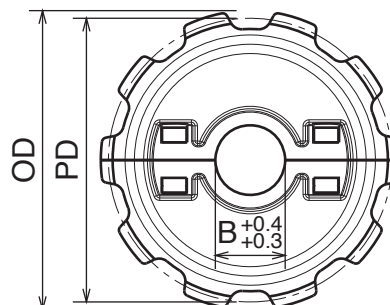

Materiale:	Material:	Materialien:
Poliammide	Polyamide	Polyamid
Viti: Acciaio inox	Screws: Stainless steel	Schrauben: Edelstahl
Dadi: ferro zincato	Nuts: zinc plated steel	Mutter: verzinkter Stahl



Ruota traino divisa, fresata / Split drive sprocket, machined / geteiltes Antriebskettenrad, gefräst

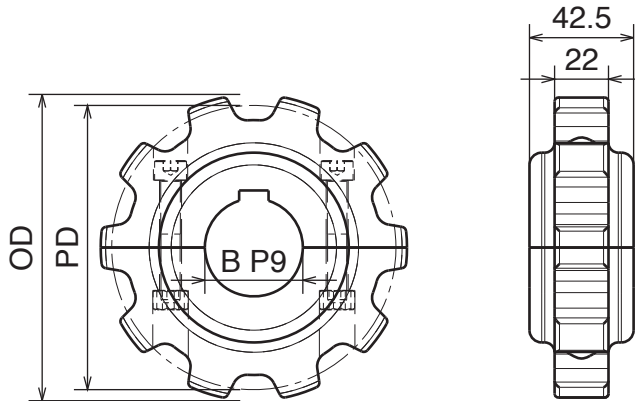

Part	Article-Nr.	Z-	Bore	PD	OD
551	55101	9	25	111,4	112,0
551	55102		30		
551	55103		35		
551	55104		40		
552	55201	10	25	123,2	125,0
552	55202		30		
552	55203		35		
552	55204		40		
553	55301	11	25	135,2	137,0
553	55302		30		
553	55303		35		
553	55304		40		
554	55401	12	25	147,2	149,0
554	55402		30		
554	55403		35		
554	55404		40		



Ruota rinvio divisa, fresata / Split idler sprocket, machined / geteiltes Umlenkrad, gefräst

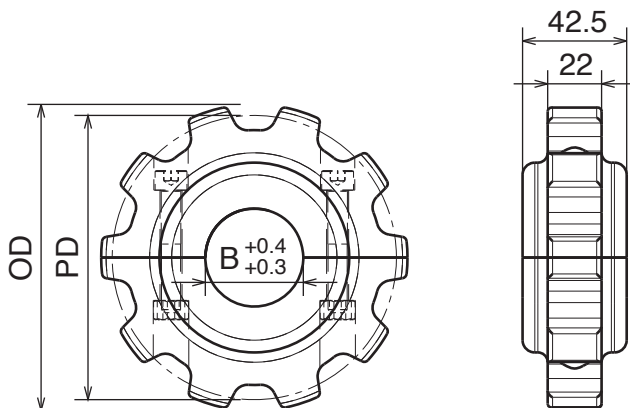

Part	Article-Nr.	Z-	Bore	PD	OD
551	55150	9	18*	111,4	112,0
551	55151		25		
551	55152		30		
551	55153		35		
551	55154		40		
552	55250	10	18*	123,2	125,0
552	55251		25		
552	55252		30		
552	55253		35		
552	55254		40		
553	55350	11	18*	135,2	137,0
553	55351		25		
553	55352		30		
553	55353		35		
553	55354		40		
554	55450	12	18*	147,2	149,0
554	55451		25		
554	55452		30		
554	55453		35		
554	55454		40		

Materiale:	Material:	Materialien:
Poliamide rinforzato	Polyamide reinforced	Verstärktes Polyamid
Viti: Acciaio inox	Screws: Stainless steel	Schrauben: Edelstahl
Dadi: ottone nichelato	Nuts: nickel plated brass	Mutter: messing vernickelt

Ruota traino divisa, stampata / Split drive sprocket, molded / geteiltes Antriebskettenrad, gespritzt

Part	Article-Nr.	Z-	Bore	PD	OD
555	55501	10	25	123,2	125,0
555	55502		30		
555	55503		35		
555	55504		40		
556	55601	12	25	147,2	149,0
556	55602		30		
556	55603		35		
556	55604		40		

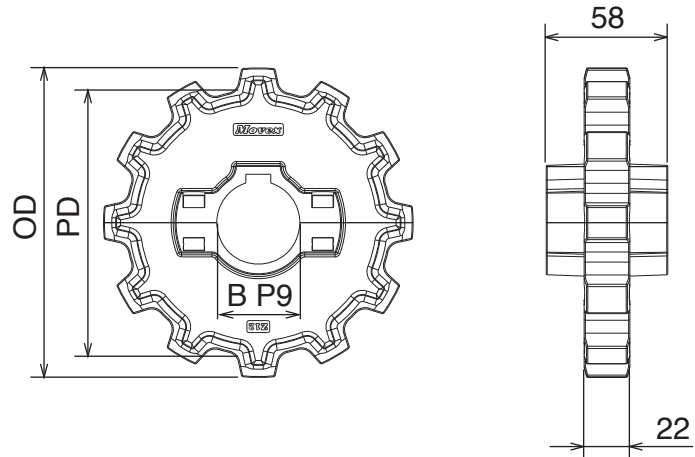

Ruota rinvio divisa, stampata / Split idler sprocket, molded / geteiltes Umlenkrad, gespritzt

Part	Article-Nr.	Z-	Bore	PD	OD
555	55551	10	25	123,2	125,0
555	55552		30		
555	55553		35		
555	55554		40		
556	55651	12	25	147,2	149,0
556	55652		30		
556	55653		35		
556	55654		40		

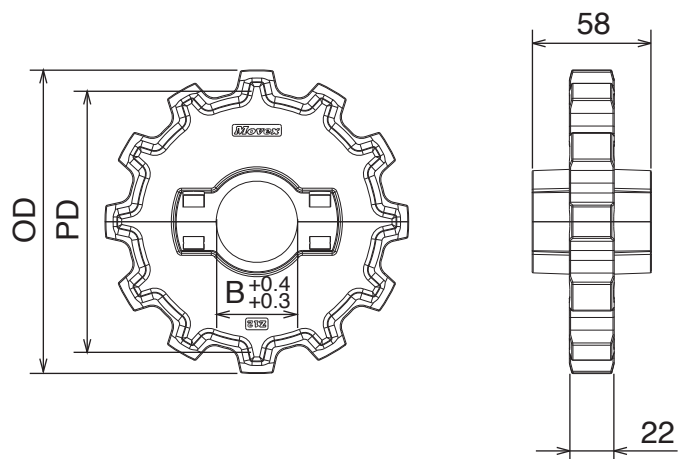

Materiale:	Material:	Materialien:
Poliammide	Polyamide	Polyamid
Viti: Acciaio inox	Screws: Stainless steel	Schrauben: Edelstahl
Dadi: ferro zincato	Nuts: zinc plated steel	Mutter: verzinkter Stahl



Ruota traino divisa, fresata / Split drive sprocket, machined / geteiltes Antriebskettenrad, gefräst

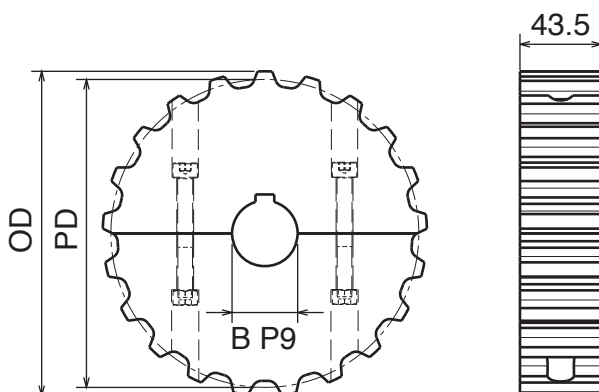

Part	Article-Nr.	Z-	Bore	PD	OD
557	55701	13	25	108,0	106,1
557	55702		30		
557	55703		35		
557	55704		40		
558	55801	15	25	124,0	122,2
558	55802		30		
558	55803		35		
558	55804		40		
559	55901	17	25	138,2	138,2
559	55902		30		
559	55903		35		
559	55904		40		
560	56001	18	25	146,3	146,4
560	56002		30		
560	56003		35		
560	56004		40		
561	56101	19	25	154,3	155,7
561	56102		30		
561	56103		35		
561	56104		40		
562	56201	21	25	170,4	173,0
562	56202		30		
562	56203		35		
562	56204		40		
563	56301	23	25	186,5	190,0
563	56302		30		
563	56303		35		
563	56304		40		
564	56401	25	25	202,7	204,0
564	56402		30		
564	56403		35		
564	56404		40		



Ruota rinvio divisa, fresata / Split idler sprocket, machined / geteiltes Umlenkrad, gefräst

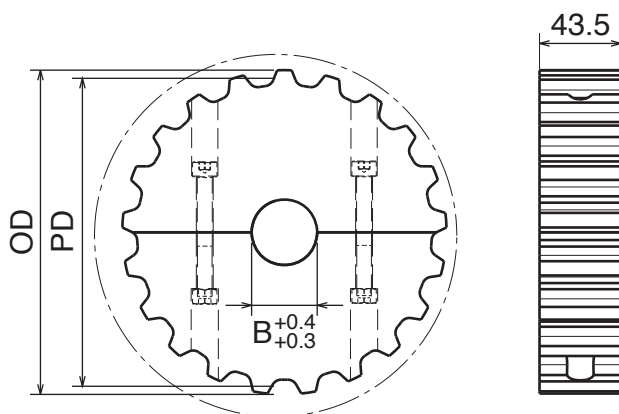

Part	Article-Nr.	Z-	Bore	PD	OD
557	55750	13	18*	108,0	106,1
557	55751		25		
557	55752		30		
557	55753		35		
557	55754		40		
558	55850	15	18*	124,0	122,2
558	55851		25		
558	55852		30		
558	55853		35		
558	55854		40		
559	55950	17	18*	138,2	138,2
559	55951		25		
559	55952		30		
559	55953		35		
559	55954		40		
560	56050	18	18*	146,3	146,4
560	56051		25		
560	56052		30		
560	56053		35		
560	56054		40		
561	56150	19	18*	154,3	155,7
561	56151		25		
561	56152		30		
561	56153		35		
561	56154		40		
562	56250	21	18*	170,4	173,0
562	56251		25		
562	56252		30		
562	56253		35		
562	56254		40		
563	56350	23	18*	186,5	190,0
563	56351		25		
563	56352		30		
563	56353		35		
563	56354		40		
564	56450	25	18*	202,7	204,0
564	56451		25		
564	56452		30		
564	56453		35		
564	56454		40		

Materiale:	Material:	Materialien:
Poliammide	Polyamide	Polyamid
Viti: Acciaio inox	Screws: Stainless steel	Schrauben: Edelstahl
Dadi: ferro zincato	Nuts: zinc plated steel	Mutter: verzinkter Stahl
Flange: Acciaio inox	Guides: Stainless steel	Bordscheibe: Edelstahl

815

Ruota flangiata divisa, fresata / Split sprocket with guides, machined / Geteiltes Kettenrad mit Bordscheibe, gefräst

Part	Article-Nr.	Z-	Bore	PD	OD	Ø screw
503	50301G	21	25	129,3	129,0	104,0
503	50302G		30			
503	50303G		35			
503	50304G		40			
504	50401G	23	25	141,2	142,0	116,0
504	50402G		30			
504	50403G		35			
504	50404G		40			
505	50501G	25	25	153,2	154,0	128,0
505	50502G		30			
505	50503G		35			
505	50504G		40			

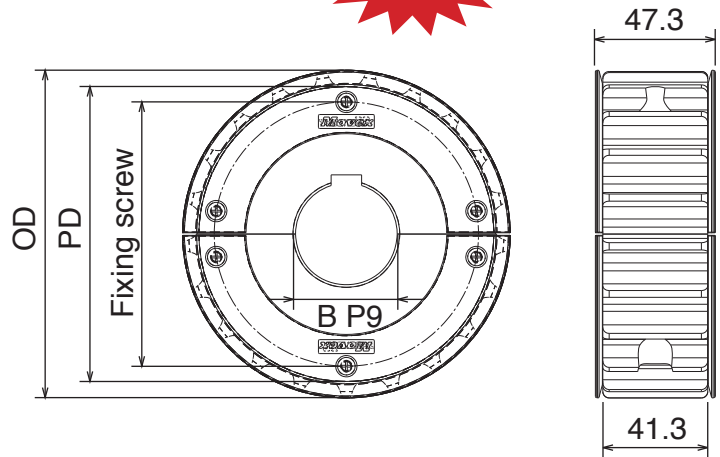

8157

Ruota flangiata divisa, fresata / Split sprocket with guides, machined / Geteiltes Kettenrad mit Bordscheibe, gefräst

Part	Article-Nr.	Z-	Bore	PD	OD	Ø screw
530	53001G	21	25	129,3	129,0	104,0
530	53002G		30			
530	53003G		35			
530	53004G		40			
531	53101G	23	25	141,2	142,0	116,0
531	53102G		30			
531	53103G		35			
531	53104G		40			
532	53201G	25	25	153,2	154,0	128,0
532	53202G		30			
532	53203G		35			
532	53204G		40			

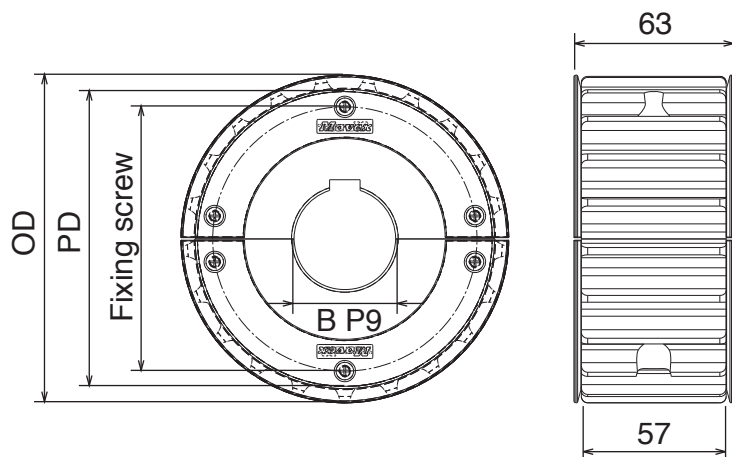

805-CC 600

Ruote Fresate
Machined Sprockets
Gefräste Kettenräder



SS rings

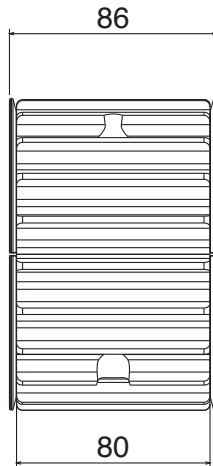
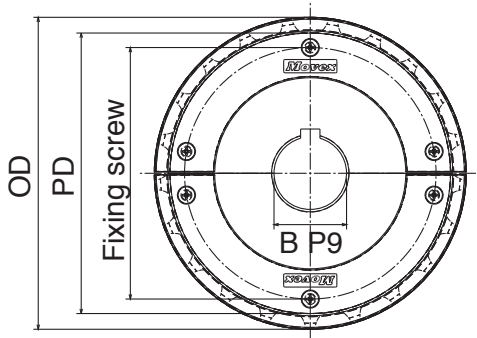

805

Ruota flangiata divisa, fresata / Split sprocket with guides, machined / Geteiltes Kettenrad mit Bordscheibe, gefräst

Part	Article-Nr.	Z-	Bore	PD	OD	Ø screw
523	52301G	21	25	129,3	129,0	104,0
523	52302G		30			
523	52303G		35			
523	52304G		40			
524	52401G	23	25	141,2	142,0	116,0
524	52402G		30			
524	52403G		35			
524	52404G		40			
525	52501G	25	25	153,2	154,0	128,0
525	52502G		30			
525	52503G		35			
525	52504G		40			



CC600

Ruota rinvio divisa, fresata / Split idler sprocket, machined / geteiltes Umlenkrad, gefräst

Part	Article-Nr.	Z-	Bore	PD	OD
565	56550	8	20	172,0	166,0
566	56650	10	20	215,0	205,0
567	56750	12	20	256,0	246,0
568	56850	14	20	297,0	286,0

For adequate quantities these sprockets can be delivered with finished bore.

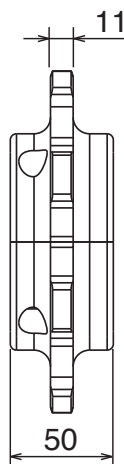
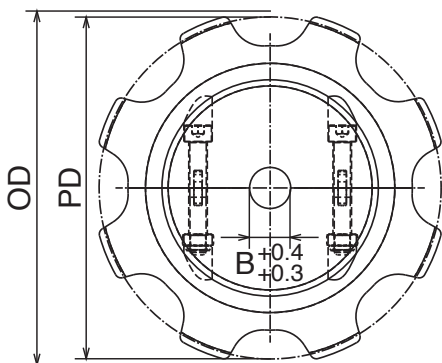



Movex S.r.l. Industrial Innovations
Via Tasso (angolo Via Noli Marenzi)
24060 Telgate (Bergamo) - Italy
Phone +39.035.8359711
Fax +39.035.4420873



Movex GmbH Industrial Innovations
Alfred-Nobel-Strasse, 4
68519 Viernheim - Germany
Phone +49.(0)6204.9375-0
Fax +49.(0)6204.9375-55



Movex Industrial Innovations UK Ltd.
Unit 7, Dene Valley Business Centre
Kineton CV35 0JD, Warwickshire - UK
Phone +44.1926.642933

Movex France - Sales Office
Phone +33.06.06.81.99.76
Fax +33.09.70.62.50.98

Movex Nederland - Sales Office
Phone +31.(0)630.99.48.50

Movex Singapore - Sales Office
Phone +65.9815.0482