

HS-100B Technical Data Sheet

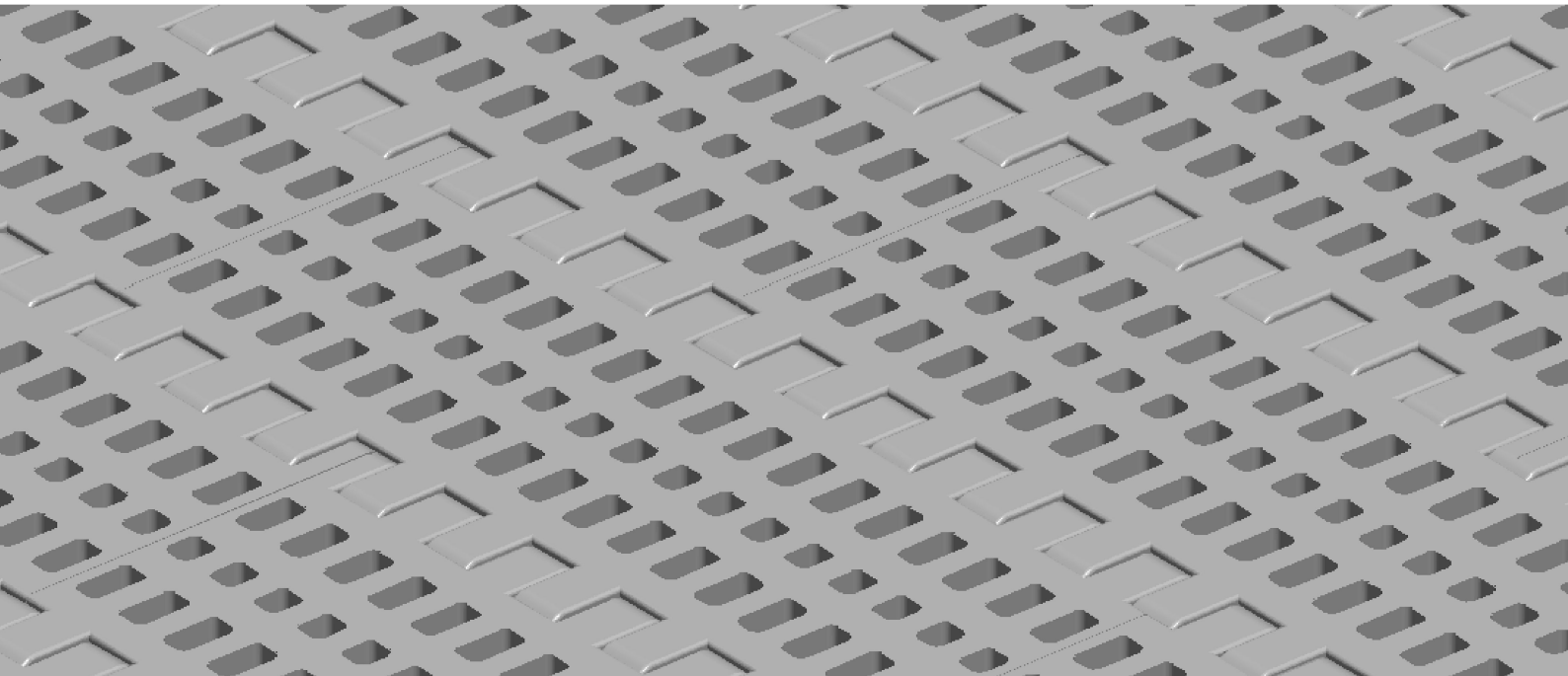

Pitch: 50.8mm Minimum Width: 150mm Open Area: 20% Approved: FDA Rod: Ø 6mm Flight: Yes Side Guard: Yes Curve: No	
---	--

Data

Belt Material	Belt Strength			Temperature		Belt Weight (Kg/M ²)
	Straight		Curve	°C (min.)	°C (max.)	
	Kg/M(BW)	N/M(BW)				
Polypropylene	1340	13400	--	1	100	7.5
Polyethylene	1280	12800	--	-60	60	8.7
Acetal	1770	17700	--	-40	80	10.2
Nylon	1520	15200	--	1	180	9.6

BW – Belt Width

Color Table

Polypropylene					Polyethylene					Acetal					Nylon				
W	G	N	DB	B	W	G	N	DB	B	W	G	N	DB	B	W	G	N	DB	B
●	●						●			●				●				●	

W-White, G-Gray, N-Nature, DB-Dark brown, B-Blue

Friction Table

Belt Material	Friction Wear strips & Products							
	UHMW	HDPE	Steel	Glass	SUS	Plastic	Cardboard	Aluminum
Polypropylene	0.32	0.24	0.15	0.09	0.13	0.08	0.15	0.25
Polyethylene	0.13	0.11	0.26	0.19	0.31	0.16	0.21	0.41
Acetal	0.11	0.09	0.27	0.16	0.26	0.15	0.19	0.28
Nylon	0.18	0.13	0.25	0.16	0.26	0.16	0.19	0.27

SUS – Stainless Steel

Equivalent type with other Brand

Brand Name	Intralox	UNI	Rexnord	MCC	Habasit	KVP
Series & Type	200	OPB	6390	2000	H5000	620
	800	L-SNB	2010		M5100	
	850	MPB	2000			

The above content is only for reference.

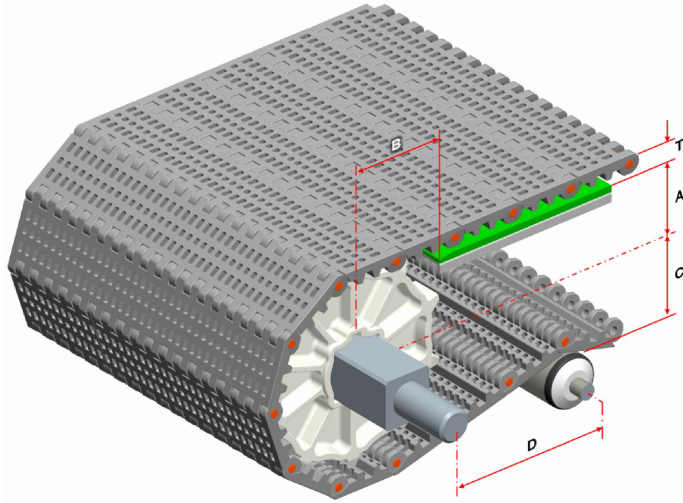

Conveyor Frame Dimensions					Unit : mm
No. Teeth	A (Min.)	B (Min.)	C (Max.)	D (Min.)	T
6	50	60	53.5	250	16
8	57	65	70	250	
10	72	82	86	250	
12	88	100	103	300	
16	121	132	136	300	

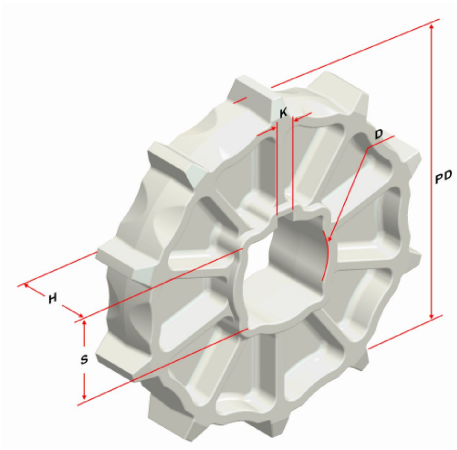

Sprocket Dimensions					Unit: mm
No. Teeth	PD	S	D	H	K
6	101.6	40.5	45.5	30	7X7
8	133	38.5/40.5	45.5	37	7X7
10	164	38.5/40.5	45.5	35	8X8
12	196	38.5/40.5	45.5	37	8X8
16	260	60.5	--	46	7X7